

Care and cleaning

Finish - We recommend cleaning with a soft dry cloth. Do not use abrasive materials as these will damage the finish.

Glass parts - Remove and wash in warm water or just use a damp cloth. Do not use abrasive materials as these will damage the finish.

Recommended bulb

1 x 40W

SES Candle

or

1 x 3W

SES LED Energy Efficient Candle Clear

or

1 x 28W

SES ECO Halogen Candle

When changing a bulb, always switch off at the mains and allow the bulb to cool before handling. Dispose of used bulbs carefully. Do not exceed the wattage stated or use a different shape bulb from that indicated on the fitting.

Specification

Maximum wattage: 40W

Voltage: 240V, 50Hz

IP Rating: 20

Weight: 0.33kg



This symbol  indicates that this product should not be treated as normal household waste and it should be recycled. John Lewis do not operate instore take back, but as members of the Distributor Trade Back scheme have funded the development and upgrade of recycling facilities across the UK. Please take it to your nearest collection facility or for further details contact your local council or visit www.recycle-more.co.uk.

We have taken great care to ensure that this product reaches you in perfect condition. However, should any parts be damaged or missing please contact our Product Helpline on (01202) 690945.

John Lewis Partnership
171 Victoria Street
London SW1E 5NN
johnlewis.com

Made in China

08/12/2020

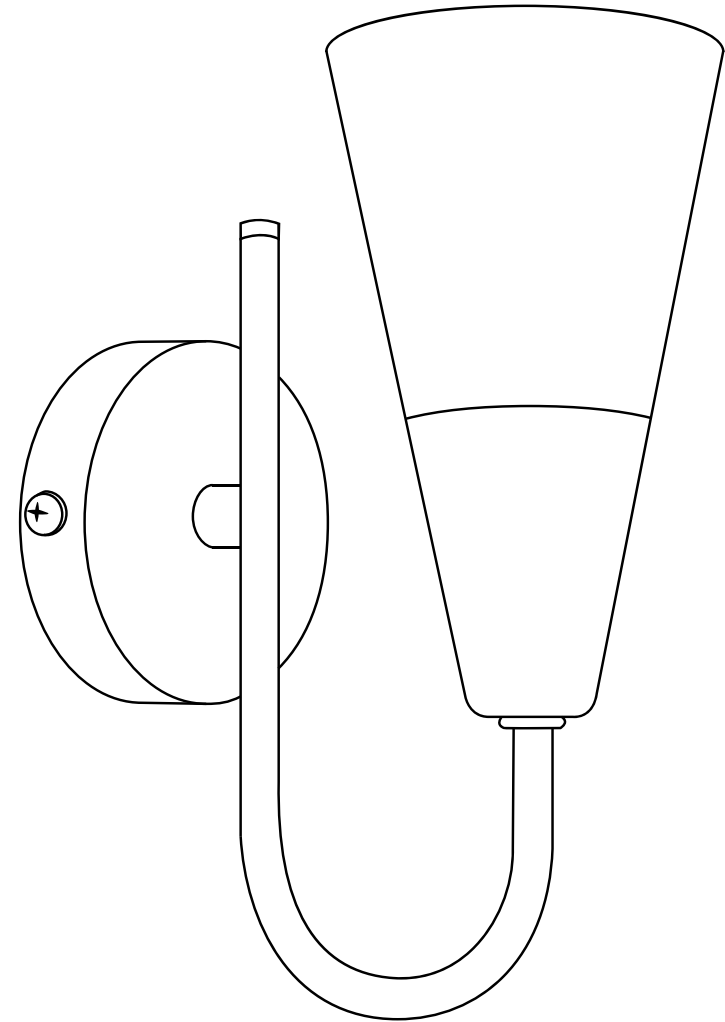

Thank you for purchasing this Lulu Wall fitting. Please read the instructions carefully before use to ensure safe and satisfactory operation of this product. Please keep these instructions for future reference.

Warnings!

This is a Class I product and must be earthed.

Please read these instructions carefully before commencing any work. It is recommended that this fitting is installed by a qualified electrician.

Install in accordance with the IEE Wiring regulations and the Building Regulations.

To prevent electrocution switch off at mains supply before installing or maintaining this fitting.

Ensure other persons cannot restore the electrical supply without your knowledge.

If you are in any doubt, please consult a qualified electrician.

This light fitting should be connected to a 5 amp fused circuit.

If replacing an existing fitting, make a note of the connections.

Always use the correct type and wattage bulb. Never exceed the wattage stated.



When changing a bulb or adjusting the heads, always switch off at the mains and allow to cool down. Dispose of used bulbs carefully.

This product is suitable for indoor use only.

This product is suitable for installation on surfaces with normal flammability e.g. wood, plasterboard, masonry. It is not suitable for use on highly flammable surfaces (e.g. polystyrene, textiles).

For your safety, always switch off the supply before changing lightbulbs, cleaning or removing shades. Always take care when handling lightbulbs to avoid injury in case of breakage.

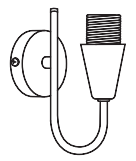
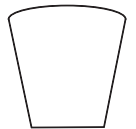
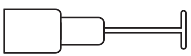
Parts List

Light fitting		1	Glass shade		1
Tool		1	Screws		2
			Wall plugs		2

Installation Instructions

Refer to assembly diagrams. Carefully unpack the carton, making sure all the parts are present before assembly.

Step 1

Remove the existing fitting, **carefully note the position of each set of wires.**

Step 2

Remove the fixing bracket from the wall back and attach to the wall using the screws provided. Take care to avoid damaging any concealed wiring and pipes.

Step 3

Having identified the household wiring from your existing light fitting, connect to the connection block inside the product in the following way:

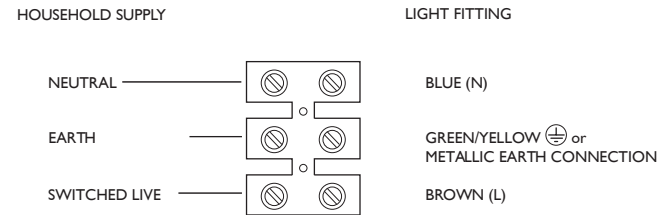

Check that.....

You have correctly identified the house wires.

The connections are tight.

No loose strands have been left out of the connection block.

Step 4

When completed, ensure that there are no bare or loose strands of wire exposed, and cover all exposed areas of the connection block with 2 layers of insulation tape.

Step 5

Ensure the arm is pointing upwards, attach the product to the fixing bracket, by refitting the screws into the holes in the wall back and tightening the screws to secure. Take care not to trap any wiring.

Attaching the shade

To attach the glass shade remove shade ring (A) from threaded body (B), place glass shade over the threaded body (B) and replace the shade ring (A), tighten with light pressure. A tool is supplied for fixing the shade ring. Please keep this for future use.

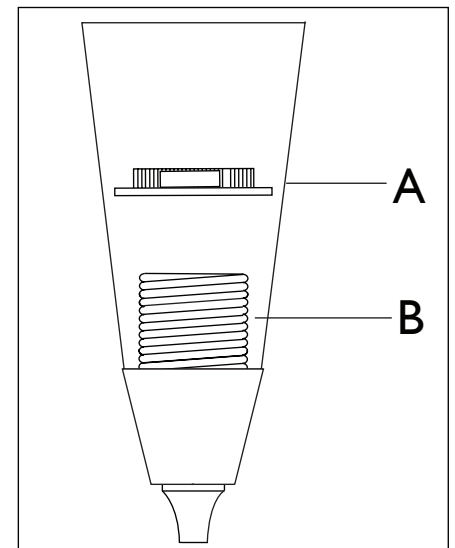

Step 6

Replace fuse or circuit breaker and switch on. Your light is now ready for use.