

Rouen Bed

Double
King
Super King

Stock Code: 803/44302
Stock Code: 803/44303
Stock Code: 803/44301

Thank you for purchasing this Rouen Bed. Please read the instructions carefully before use to ensure safe and satisfactory operation of this product.

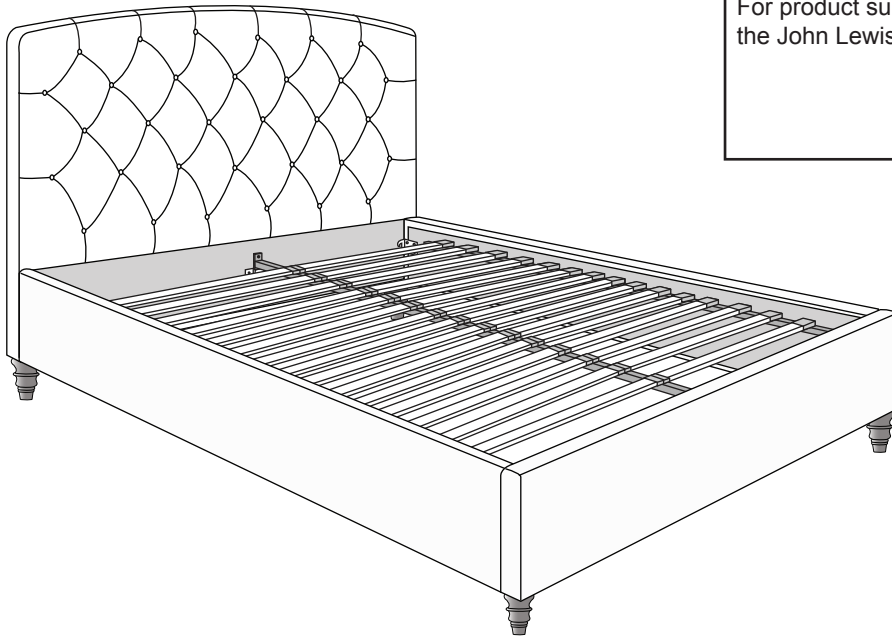

For product support or spare parts please call the John Lewis Helpline;
T: 01244 689949
E: mail@fwgroup-uk.com

PRE-ASSEMBLY PREPARATION

Please ensure instructions are read in full before attempting to assemble this product.

Necessary Tools

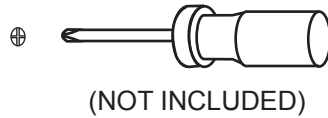
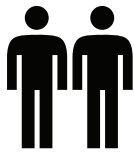

(NOT INCLUDED)



Please check the pack contents before attempting to assemble this product. A full checklist of components is given in this leaflet. If any components are missing, please contact the John Lewis Helpline.

This product is **HEAVY**. It should be assembled as near as possible to the point of use. **TAKE CARE WHEN LIFTING** to avoid personal injury and (or) damage to the product.

This product takes approximately **40 MINUTES** to assemble with **2 PEOPLE**.







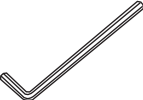

The fittings pack contains **SMALL ITEMS** which should be **KEPT AWAY FROM YOUNG CHILDREN**.

Read this leaflet in full before commencing assembly.

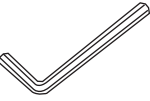
If you require any additional information or have any issues with this product please call the John Lewis Helpline on 01244 689949 or email mail@fwgroup-uk.com

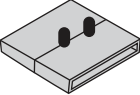
Fittings and parts checklist

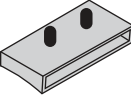
Fittings

A	M4 Allen Key x 1		F		M8 Spring Washer x 2
B	M5 Allen Key x 1		G		Nut M8 x 2
C	Centre Caps x 15		H		Screw 3.5 X 30mm x 2
D	Side Caps x 30		I		Spanner M13 x 1
E	M6 X 25mm Bolt x 6				

Parts

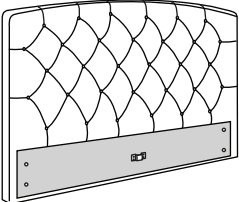
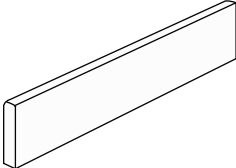
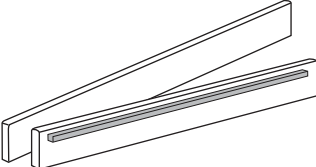
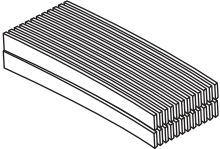
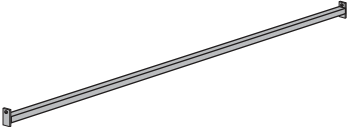
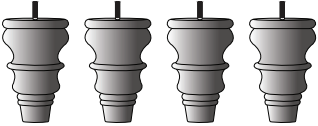
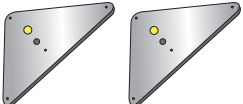
1	Headboard x 1	
2	Footboard x 1	
3	Side Rails x 2	
4	Slats x 30	
5	Centre Rail x 1	
6	Legs x 4	
7	Metal Plates x 2	

Step by step assembly instructions

Step One

Place Metal Bracket on Side Rails (3) over pre-inserted bolts in Headboard (1) and Footboard (2) and hand-tighten to loosely secure parts together. Do not tighten bolts with M5 Allen Key (B) until you have inserted the Centre Rail in the next step.

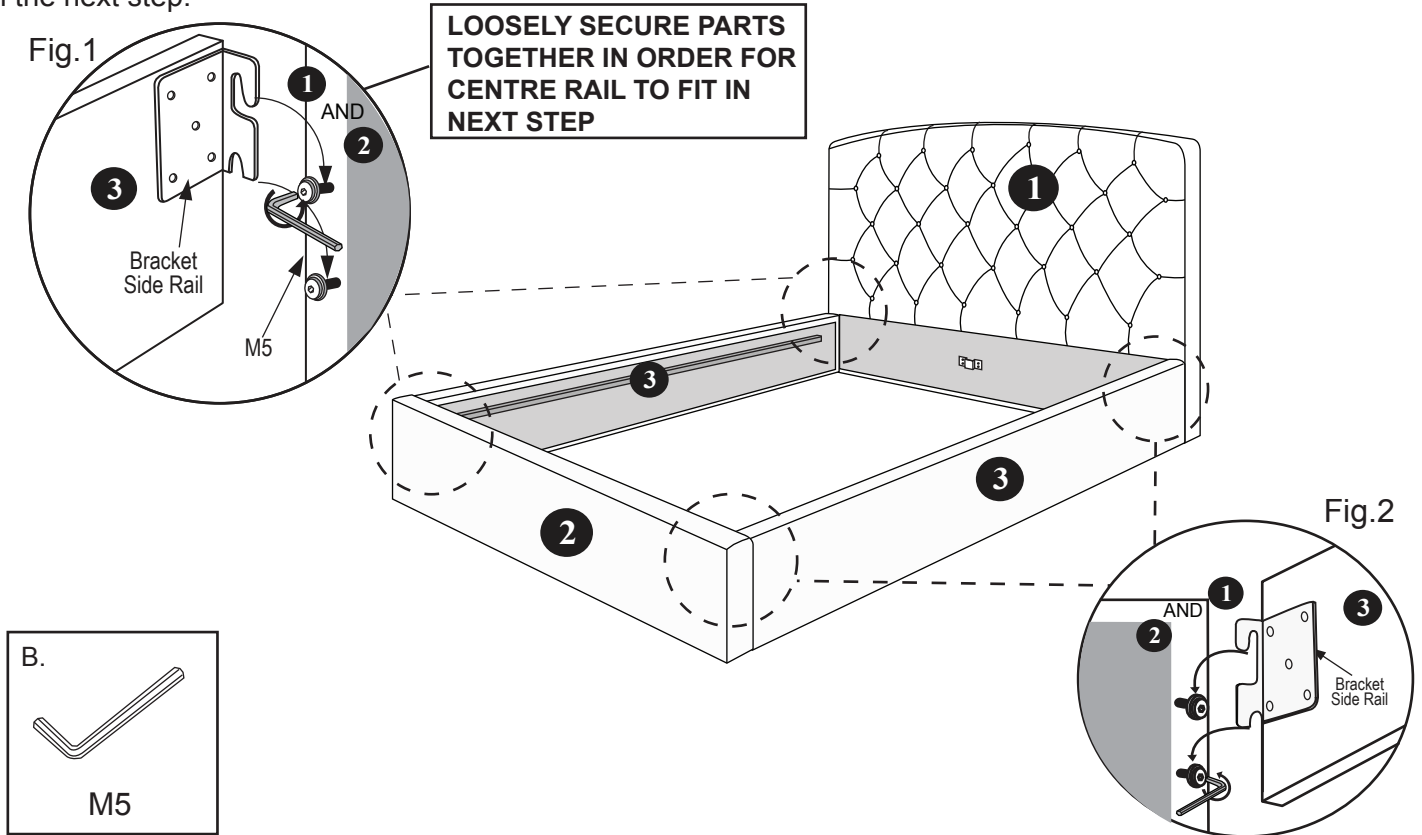

Step Two

Lower the Centre Rail (5) into the brackets in the centre of the Headboard (1) and Footboard (2) as shown in fig.3. Now secure the Centre Rail (5) using M6 x 25mm Bolts (E) and tighten with M4 Allen Key (A) as shown in fig.4. You can now tighten the bolts at the Side Rails from previous step (Step One) with the M5 Allen Key (B) so all fastenings are now tightened.

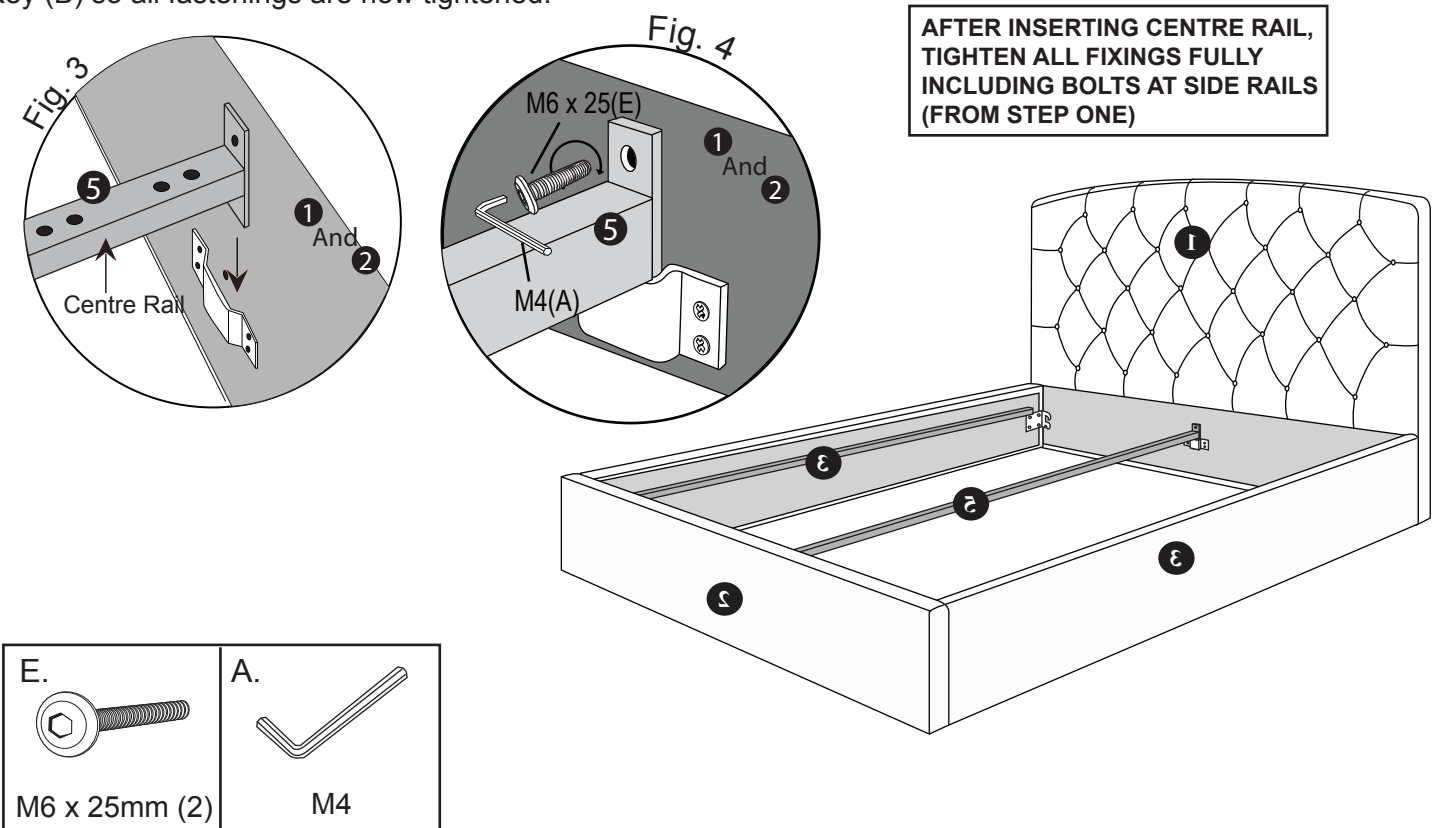

Step Three

Starting with the Headboard (1), insert the Front Legs (6)x2 into the pre-drilled holes on the underside of the Headboard (1) and twist to secure, as shown in the diagram below.

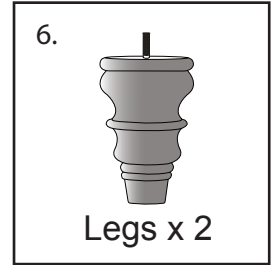
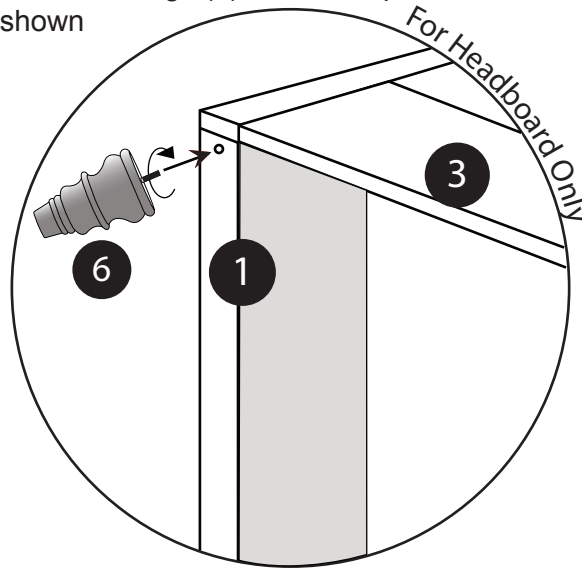

Step Four

Attach the Metal Plate (7) to the bottom of Footboard (2) using bolt M6 x 25mm (E)x2 and Screw 3.5 x 30mm (H)x1. Tighten the bolt with M4 Allen Key (A). Repeat process for other Footboard Leg. Next, insert Wooden Leg (6) into the bottom of Metal Plate (7) using Spring Washer (F)x1, M8 Nut (G)x1 then tighten with Spanner M13 (I).

For Footboard Only

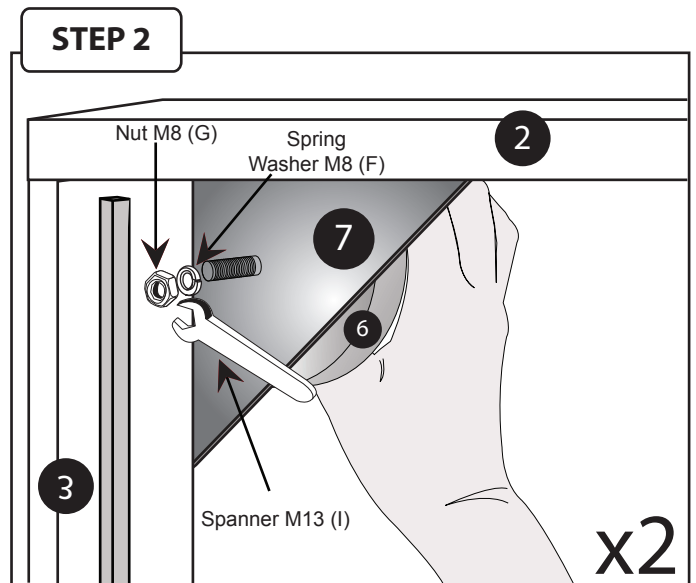
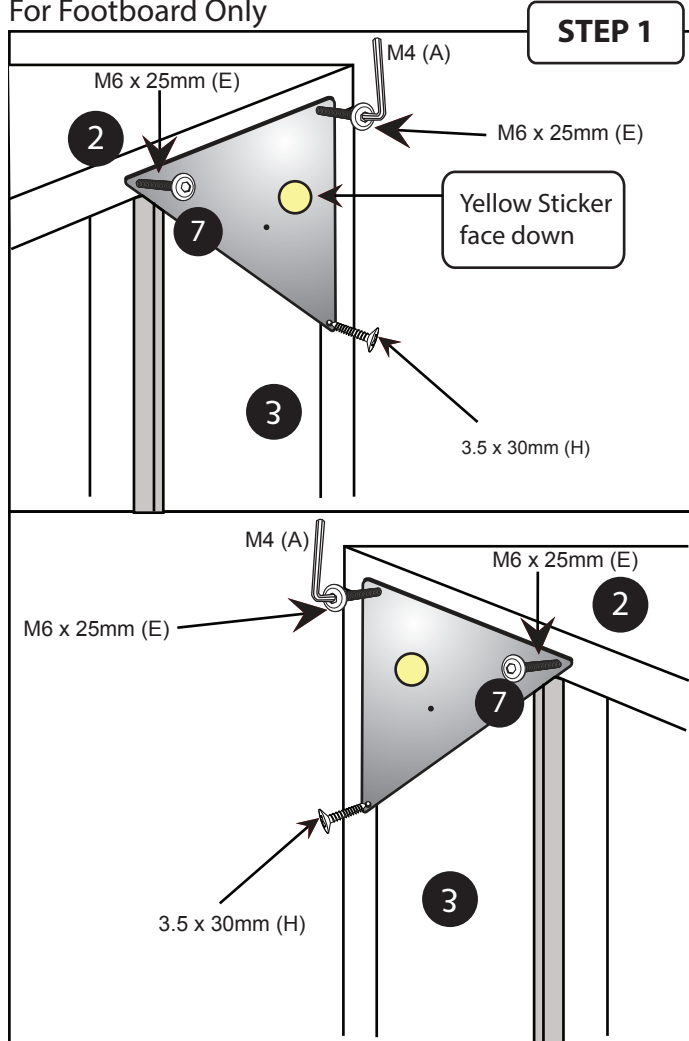

F.	6.	7.	I.	G.	H.	E.	A.
Spring Washer M8 (2)	Legs (2)	Metal plates (2)	Spanner M13 (1)	Nut M8 (2)	Screw 3.5 x 30mm (2)	M6 x 25mm Bolt (4)	M4 Allen Key (1)

Step Five

Starting at the headend, insert the Centre Caps (C) along the Centre Rail (5). Ensuring that the Slats (4) are facing curved side up, insert into the Centre Caps (C). Place a Side Cap (D) onto the other end of the Slats (4) and push down fully into the pre-drilled holes along the Side Rails (3), as shown in the diagram below. Repeat this process to attach all 30 Slats (4).

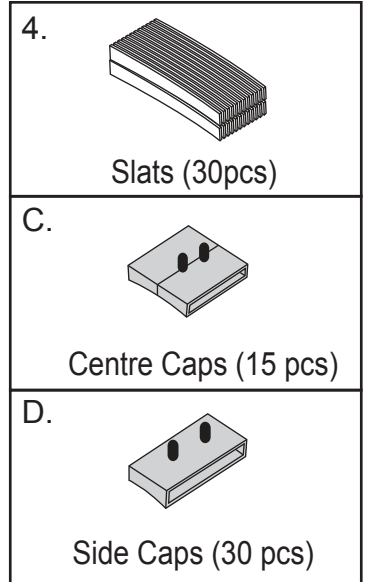
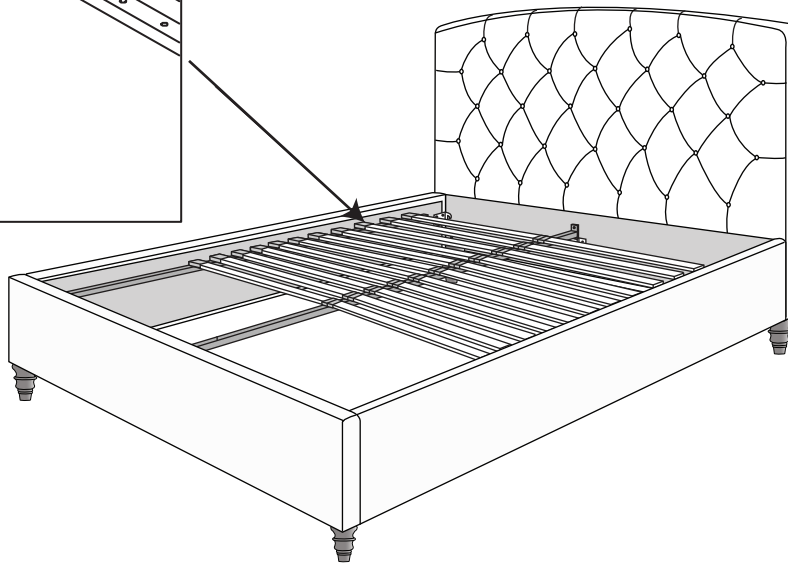
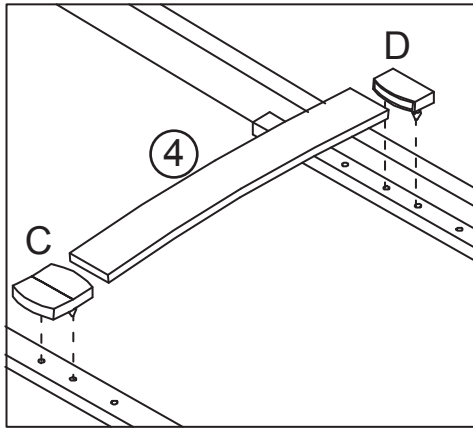

Step Six

This bed is now ready to use.

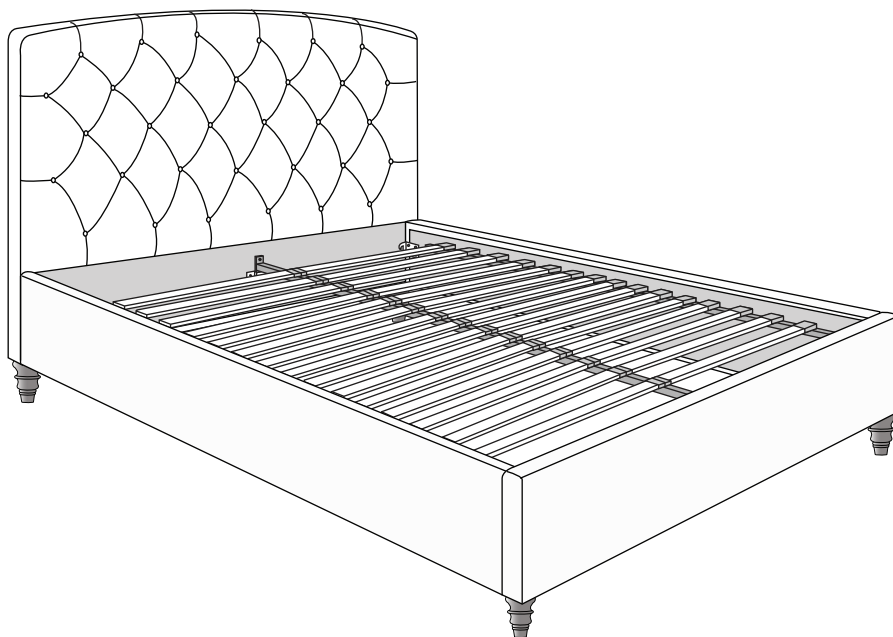

Care and Maintenance

This Rouen bed should be cleaned using a soft, damp cloth and dried immediately. Do not use a very wet cloth or allow any liquid contact for a long period of time as this can permanently damage the surface.

Do not use detergents and do not rub as this can cause permanent damage.

Always protect your bed from direct sunlight as this may accelerate the natural ongoing discolouration process.

Screws holding together the bed frame should be tightened regularly.

Please retain this information leaflet for future reference.

This product complies with BS EN 1725:1998.

Safety Instructions

Never drag furniture when moving it. Always lift it.

Periodically check all fixings to ensure none have come loose and re-tighten where necessary.

Please take care when handling or moving the furniture as careless handling may cause damage or injury.

Furniture can be dangerous if incorrectly installed. Any assembly should be carried out by a competent adult.

No liability will be accepted for damage or injury caused by incorrectly installed or assembled furniture.

During assembly, children should be kept away from the product due to possible risk of injury.

Do not use this item if any components are missing or damaged.

It is recommended that care is taken when moving heavy objects to a new location to avoid personal injury or damage to the furniture. Please be careful to retain all fittings when doing this.

If you require any additional information or have any issues with this product please call the John Lewis Helpline on 01244 689949 or email mail@fwgroup-uk.com

John Lewis Partnership 171 Victoria Street, London, SW1E 5NN.
www.johnlewis.com